

## CONLOC® UV 690

### UV Adhesive

is a high-viscosity, one component, solvent- free adhesive which cures photochemically when exposed to UV light.

#### TYPICAL USES

For bonding glass/glass. **CONLOC UV 690** is neither suited for outdoor applications nor for the construction of aquaria. The product may yellow when exposed to temperatures higher than room temperature.

#### APPLICATION

Adhesion surfaces must be dry, clean and free from dust and substances liable to impair adhesion. For the final cleaning process use **EGO CLEANER SOFT**. Common glass cleaners and detergents are unsuitable. Non observance may lead to reduced bond strength. Apply the adhesive sparingly but in sufficient quantity and without bubbles to one of the adhesion surfaces. Join the parts without tension with a gap width of min. 0.05 mm and max. 0.2 mm. The adhesive is cured by suitable UV lamps. For bonding laminated glass we recommend to use our daylight-curing grade **CONLOC UV 680**.

Meets Requirements of IVD Instruction Sheets No. [35](#)

#### TECHNICAL DATA

Properties	Result
Material Basis	Acrylate
Refraction Index	Approx. 1.5
Density	Approx. 1.1 g/cm <sup>3</sup>
Solids Content	100%
Flash Point	> 95°C
Viscosity	Approx. 2500 mPa·s
Consistency	High viscosity
Gap Width	0.05 - 0.2mm
Irradiation	UVA 320-400nm
Use of Activator 953	No
Hardness Shore D	Approx. 60
Tensile Shear Stength	10 N/mm <sup>2</sup> (see page 3)
Linear Shrinkage	Approx. 1 %

#### AVAILABILITY AND STORAGE

Standard Colour	Clear
Packaging	Plastic bottles of 20 g, 100 g and 250 g
Storage	Store in dry and dark conditions (without UV exposure) in original, unopened container. Shelf life in normal conditions 6 months.



Qualitäts-  
Produkte

SAFETY INSTRUCTIONS

Meets Requirements of	REACH Regulation (EC) No. 1907/2006 and No. 1272/2008 CLP
Labelling	See EC safety data sheet
Safety Guidelines	See EC safety data sheet
Disposal	See EC safety data sheet

Precautions see EC Security Data Sheet. The above specifications are the result of careful research and development. All previous specifications are hereby null and void. Users are themselves responsible for ensuring the suitability of the product for the purpose intended, liability on the part of EGO being limited to the purchase price of the material. EGO cannot accept liability for damage, in particular that caused by the use of the product or its unsuitability, nor can EGO accept responsibility for unauthorized recommendations or guarantees which deviate from or exceed the specifications given in this product data sheet.

EGO Dichtstoffwerke GmbH & Co. Betriebs KG • Kaltenbrunn 27 • D-82467 Garmisch-Partenkirchen

Fon +49 8821 95 69 0 • Fax +49 8821 95 69 90 • Mail info@ego.de

www.ego.de

Page 2 of 3

Technical data sheet CONLOC UV 690

Version 12/22



Member of the Bundesinnungsverband des Glaserhandwerks



Member of the Industrieverband Dichtstoffe e. V. (IVD)



Member of the Institut für Fenstertechnik e. V. Rosenheim



ISO 9001:2015



ISO 14001:2015

In addition to the technical information given in this technical data sheet please also observe the relevant DIN standards as well as the rules and regulations of the various professional associations when planning your project.

The information given and the suggestions made for the application of our products are based on our use-oriented tests, our product and technical know-how as well as on our practical experience. Because of conditions of use and application outside of our control and the large number of different materials, the user is advised to conduct his own tests in order to determine the suitability of our products for his particular application.

In general we recommend to bond the parts in question and then test the strength of the bond (impacts, movement etc). Please also take into account the thermal stress to be expected. In case of questions please contact us for advice.

Whilst every care has been taken in the preparation of this information, no warranty is given or implied in connection with any recommendation or suggestion made herein.

Please note that with the appearance of this data sheet all previous data sheets become invalid.

### *Tensile shearing strength test specification*

(see technical data)

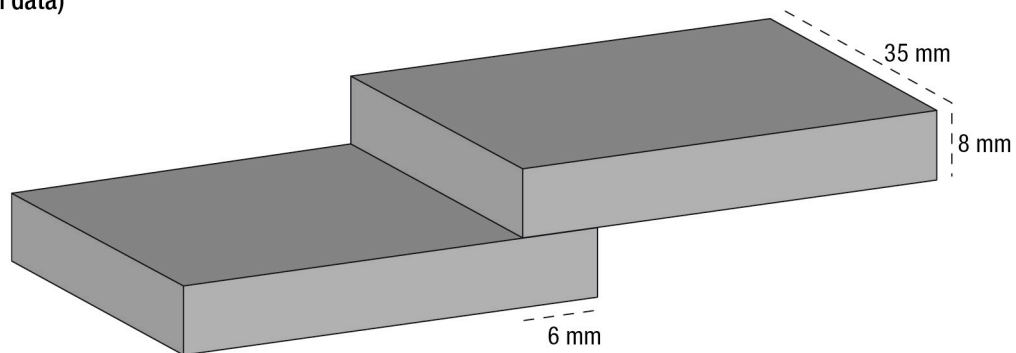

- referred to a bonding surface of 6 x 35 mm, overlapping
- GLASS/GLASS bonding
- UV irradiation is possible with suitable UV lamps
- measured normal climate conditions +23 °C (50 % relative humidity)
- Speed of removal 1 mm/minute
- Substrate cleaning using CONLOC® Cleaner 902